

# PRODUCT SPECIFICATIONS

## FULL BORE BALL VALVES

### MODEL 840S

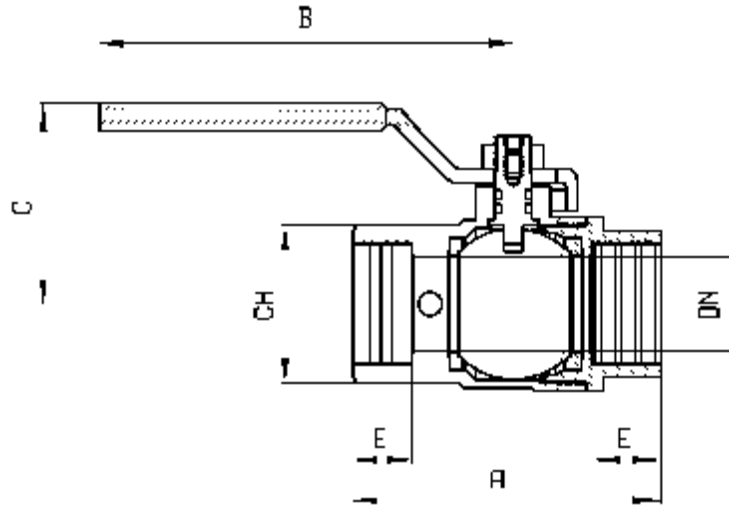

Dimensions	A		B		C		CH		DN		E	
	mm	in	mm	in	mm	in	mm	in	mm	in	mm	in
1/2	52.5	2.07	88.0	3.46	38.2	1.50	25.0	0.98	15.0	0.59	10.0	0.39
3/4	62.3	2.45	88.0	3.46	41.7	1.64	31.0	1.22	20.0	0.79	11.5	0.45
1	71.5	2.81	105.0	4.13	47.5	1.87	38.0	1.50	25.0	0.98	13.5	0.53
1 1/4	83.0	3.27	105.0	4.13	53.0	2.09	47.0	1.85	32.0	1.26	15.0	0.59
1 1/2	94.0	3.70	134.0	5.28	65.0	2.56	54.0	2.13	40.0	1.57	16.0	0.63
2	107.0	4.21	134.0	5.28	72.5	2.85	67.0	2.64	50.0	1.97	16.0	0.63

#### Features:

- Double Viton stem seals, Teflon Seats, Teflon thrust washer.
- Low torque operation. Reversible handle.
- Thicker, heavier, more substantial body.
- Nickel plated body includes two ¼ inch pilot/test ports.
- Wider wrench flats. Threads to ANSI B1.20.1.
- Forged brass for extra strength.
- Rating 600 CWP (cold working pressure), 150 psig saturated steam.
- UL listed gas shut-off, manual valves 20G.
- ISO 9001 manufacturing - American National Standard ANSI/ASQC Quality Systems.
- Meets many international standards including those of Germany, Switzerland, Australia, Denmark, Czech Republic, and Poland.

### COMBU INC.

**P.O. BOX 974, PARSONS, KS 67357**  
**Phone 620-421-0480 Fax 620-421-0948**